

# DI5100

4 CHANNEL WEIGHT CONTROLLER

An mid-range weighing controller for

- ✓ OEM's
- ✓ PLC Integrators
- ✓ EPC's
- ✓ Dealers & End users

Value for money

## Unique Feature

Helps troubleshooting by monitoring status of all 4 loadcells individually.

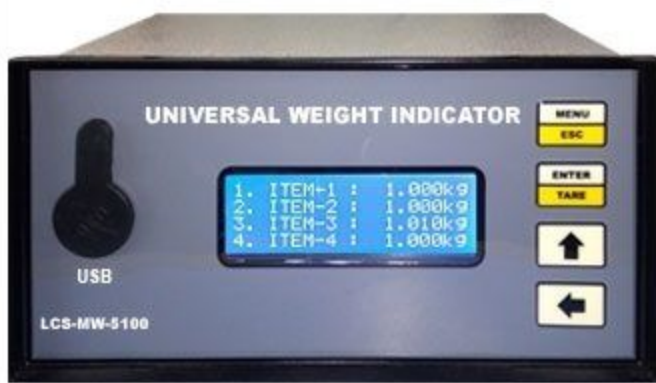

## FEATURES & SPECIFICATIONS

- High speed controller.
- 4 x 20 Character - LCD Display
- Four Channel Loadcell Inputs.
- High accuracy with 20 bit resolution
- 4 Digital Input (Low Logic)
- 5 Digital Output - 24V DC / 1A (Potential free contact)
- One Serial Port i.e RS232C.
- One USB Port for Pendrive access.
- Automatically stores weighing data with date / time
- Dimension - 92 x 186 mm panel cutout, Depth - 120
- Power Supply - 24VDC / 0.5A, max 25W

## APPLICATION

- Concrete Batching
- Tank / Silo Weighing
- Liquid Filling
- Bagging
- Multi component batching

## SCHEMATIC

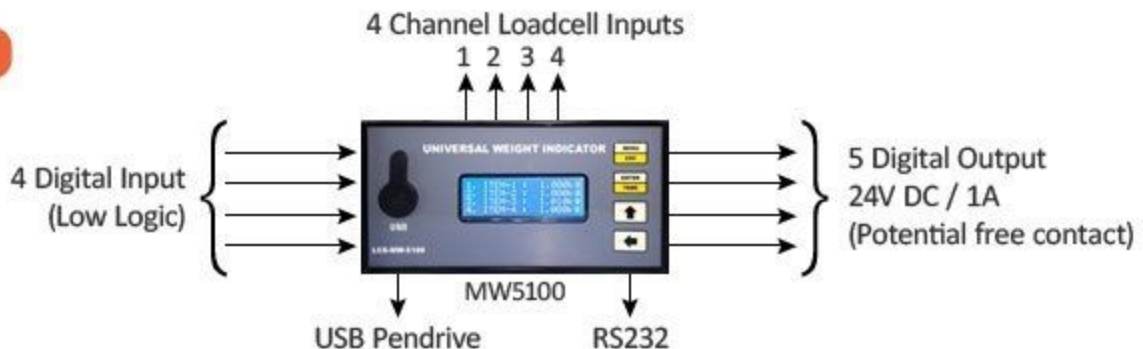

Please Communicate to :

# EPOCH

**Instruments & Controls Pvt. Ltd.**

Factory : No. 16, Bhadrappa Este, 54, Magadi Main Road, Kamakshipalya, Bangalore – 560 079.

☎ : 080 – 2348 1364, 6576 1259. ☎ : 080 – 2328 3728. E-mail : sales@epochloadcell.com